

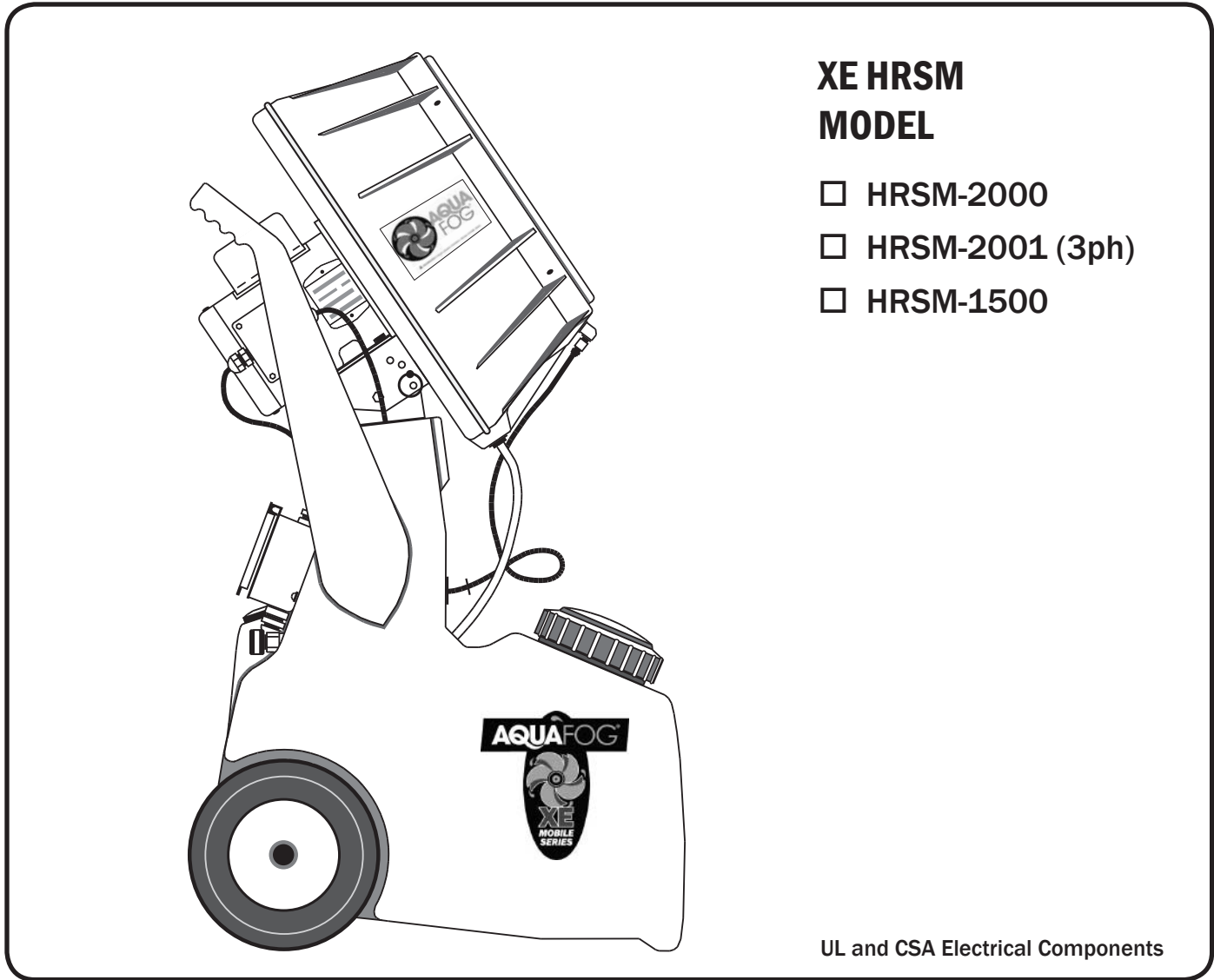

# XE MOBILE ATOMIZER

## USER'S MANUAL AND OPERATING INSTRUCTIONS



### XE HRSM MODEL

- HRSM-2000
- HRSM-2001 (3ph)
- HRSM-1500

UL and CSA Electrical Components

## OPERATOR'S MANUAL



**NOTICE**

Read & Understand  
Retain for Future Reference



# GENERAL SAFETY

Since the mobile HRSM uses high-speed components to atomize liquids, the following safety precautions must be observed at all times:

1. Read all manuals included with this product. Be familiar with the product and controls.
2. The HRSM is intended to be used on level ground. Test for stability before operation.
3. Follow United States Environmental Protection Agency (EPA) guidelines and regulations when fogging pesticide or chemical solutions.
4. Follow all local electrical and safety codes as well as the United States National Electrical Codes (NEC) and Occupational Safety and Health Act (OSHA).
5. Only persons well acquainted with these rules of safe operation should be allowed to use the atomizer.
6. Keep visitors away and NEVER allow children in the work area.
7. Use of an extension cord for the HRSM is not recommended. If necessary, refer to the A.W.G chart in the following section or consult a certified electrician.
8. Before each use, inspect blade assembly and electrical components for signs of damage, deterioration, weakness or leakage. Repair or replace defective items before using.
9. Check all fasteners at frequent intervals for proper tightness.



## **WARNING**

**MOTORS, ELECTRICAL EQUIPMENT AND CONTROLS CAN CAUSE ELECTRICAL ARCS THAT WILL IGNITE FLAMMABLE LIQUID OR GAS. NEVER OPERATE OR REPAIR IN OR NEAR FLAMMABLE LIQUID OR GAS. NEVER STORE FLAMMABLE LIQUIDS OR GASES IN THE VICINITY OF THE ATOMIZER.**

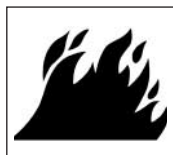

## **DANGER**

### **HIGH-SPEED ROTATION**

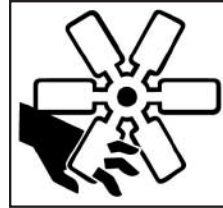

A motionless atomizer may appear safe, but its blade could suddenly begin high-speed rotation without warning as a result of control programming.

When the HRSM is automated by controls, warning signs should be posted near the high-speed equipment.

Disconnect and lock out power source to inspect or service the unit.

## **WARNING**

### **NEVER OPERATE HRSM WITHOUT THE SAFETY GUARD**

**IN PLACE UNLESS THE UNIT IS RAISED SEVEN FEET ABOVE WORKING HEIGHT.**

10. Keep fingers away from a running unit; fast moving and hot parts will cause injury and/or burns.
11. If the equipment starts to vibrate abnormally, STOP the motor and check immediately for the cause. Vibration is generally an indication of trouble.

## **Fogging Precautions**

## **DANGER**

### **DO NOT ATOMIZE FLAMMABLE MATERIALS.**

12. Humidity and cold air are two common asthma triggers. Asthmatic people working with this equipment need to be made aware of the risk.

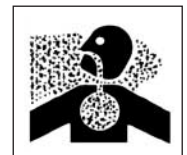

13. When atomizing toxic chemicals, follow the instructions provided by the chemical manufacturer.

# GETTING STARTED

## UNPACKING CHECKLIST ✓

**⚠ WARNING** DO NOT OPERATE UNIT IF DAMAGED DURING SHIPPING, HANDLING OR USE. DAMAGE MAY RESULT IN BREAKAGE AND CAUSE INJURY OR PROPERTY DAMAGE.

- ✓ Un-crate carefully and position HRSM on level ground.
- ✓ Save crate and packing materials until evaluation and testing are complete.
- ✓ Read manual carefully and understand all instructions.
- ✓ Do not connect power until after thorough inspection and filling the sump with liquid.
- ✓ After filling the unit with some liquid, inspect for leaks.
- ✓ Never operate without liquid in tank.
- ✓ Be sure guards are securely in place and warnings are clearly visible.
- ✓ Check power supply for correct voltage.

## ELECTRICAL

**⚠ WARNING** GROUND FAULT RECEPTACLES ARE RECOMMENDED AND MAY BE REQUIRED BY LOCAL AND/OR NATIONAL CODE.

**⚠ NOTICE** USE OF AN EXTENSION CORD IS NOT RECOMMENDED. IF NECESSARY, REFER TO FIG. 12.

**Fig. 12**

EXTENSION CORD SPECIFICATIONS*		
FOR SINGLE FAN USE ONLY • (AWG - American Wire Gauge)		
Voltage	25 to 50 ft.	50 to 100 ft.
115	14 AWG	12 AWG
230	16 AWG	14 AWG



\*Grounded and suitable for outdoor use.

## UNIT PREPARATION

Visually check to make sure that the critically important liquid feed tube (Part #6) has maintained its center position, partially inserted into the blade assembly. Re-position if necessary. (See Fig. 1)

Visually check to make sure the blades can rotate freely without touching any venturi pins. There should be approximately 1/4" space between the pins and the blades. (See Fig. 2) Do Not operate if blades may hit pins. Refer to troubleshooting for adjustments.

**Fig. 1**

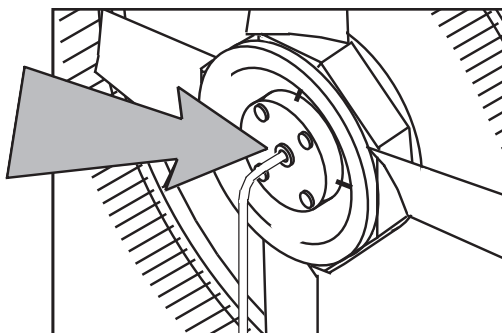

**⚠ WARNING** ENSURE THE BLADE ASSEMBLY IS CENTERED INSIDE THE PINNED VENTURI. ADJUST MOTOR AND BLADE AS NECESSARY.

**Fig. 2**

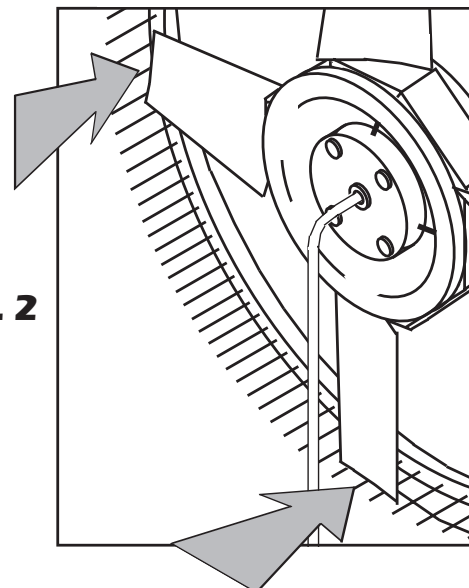

# CONTROLS/ FEATURES

## Flow Control /Strainer /Pivot

The volume of fog can be regulated by adjusting the Flow Control Valve. (See Fig. 3)

Particle size is smaller at lower outputs, so it is better to operate the unit at a lower output for longer periods of time.

At the base of the plumbing is an in-line strainer with a removable cap. Periodically check inside and flush any sediment from the screen. (See Fig. 3)

The HRSM is equipped with a four position pivoting fogging head with 15° intervals up to 45°. Propelling the fog upward allows more time for the particles to evaporate, keeping floor areas drier.

When making an adjustment, balance the weight of the fogging head off of the pin for easy removal. (See Fig. 4)

**Fig. 3**

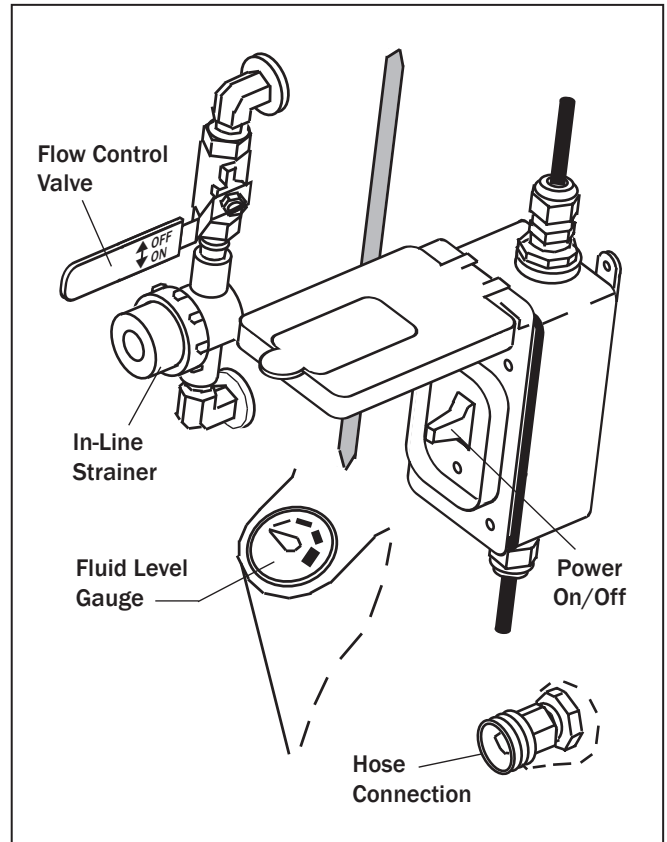

**Fig. 4**

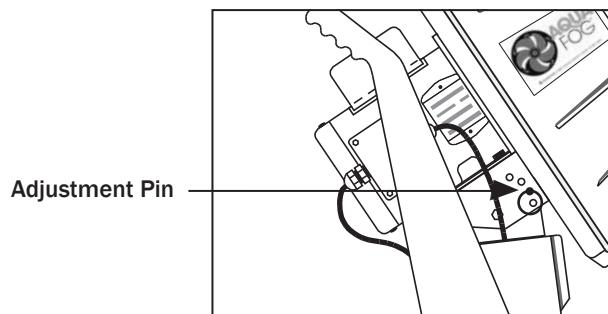

# INSTALLATION

## SETUPS

### A) Automated Operation

Connect the unit's power cord to a power supply controller and switch on the unit's toggle switch.

### B) Manual Operation

Plug unit into an available dedicated 20A power supply and use the unit's On/Off toggle switch to control operation.

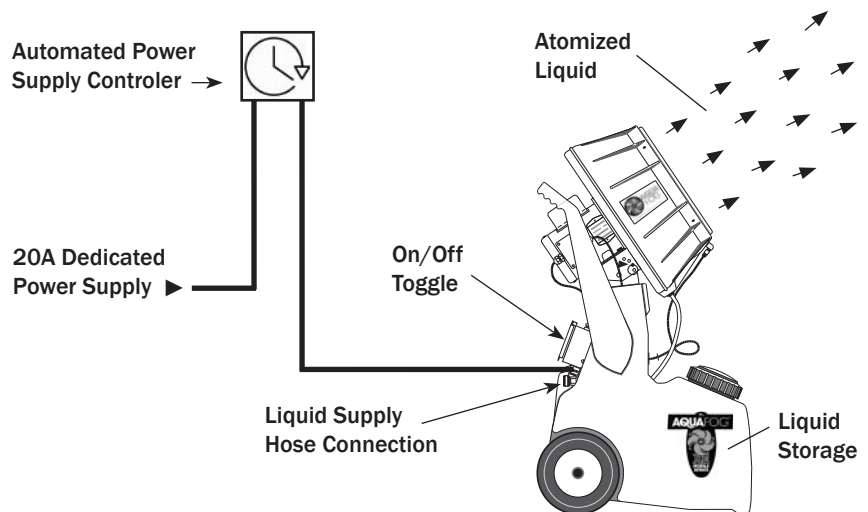

# TESTING AND EVALUATION

## **⚠ DANGER**

**BEFORE TESTING FAN MAKE SURE ALL OBJECTS ARE OUT OF THE ROTATION PATH OF THE FAN BLADES. HIGH-SPEED WARNING. KEEP HANDS CLEAR! MAKE SURE GUARDS ARE INSTALLED OR UNIT IS OUT OF REACH.**



- ▶ For first-time evaluation, fill tank (with water only) about one quarter full.
- ▶ Connect to power supply.
- ▶ BUMP START HRSM and check for proper fan blade rotation (clockwise if looking at front of unit). If incorrect, find rotation connection changes on the motor's electrical schematic.

## **⚠ CAUTION**

**CAREFULLY LISTEN FOR UNUSUAL NOISE OR VIBRATION.**

- ▶ Turn on the unit and listen for any possible abnormalities, such as the blades rubbing against the venturi. Make re-adjustments if necessary.
- ▶ Evaluate fog quality adjusting the output by using the flow control valve. (See Fig. 3). After starting, it generally takes several seconds for the liquid to reach the atomizing fan.

# ELECTRICAL SCHEMATICS

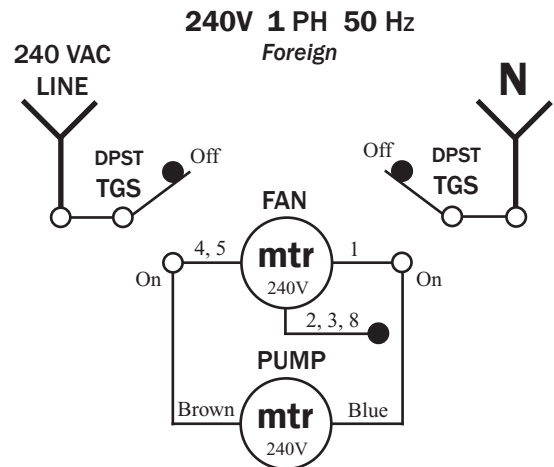
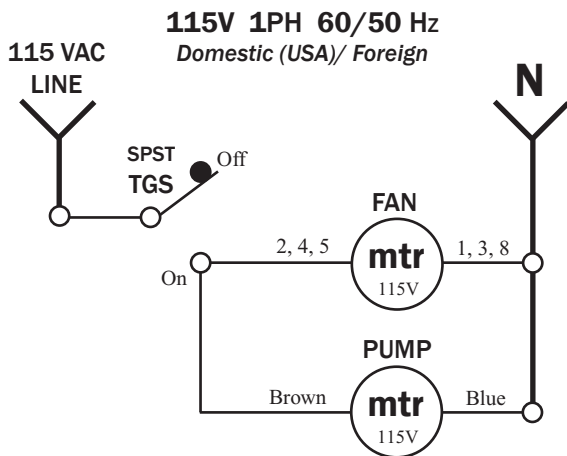

**208-230V 3PH 60Hz**  
Domestic (USA)

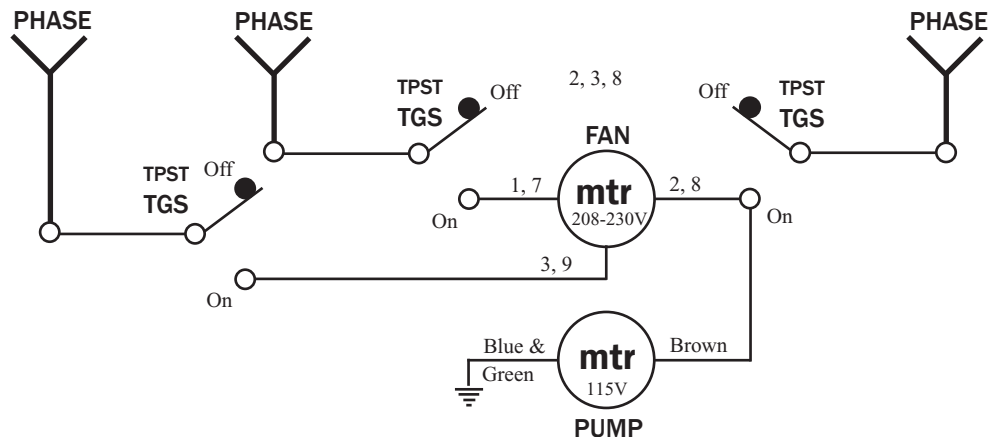

○ Denotes Line Connection

● Denotes Termination

Note: All green wires go to ground

# TROUBLESHOOTING



## **WARNING**

**BEFORE INSPECTION AND /OR SERVICE  
DISCONNECT AND LOCK OUT POWER SOURCE.**

---

### **1. Fan Does Not Operate**

- A.) Check voltage requirements on unit and electrical supply. Check for live receptacle, plug, power line and toggle switch.
- B.) Look for any loose connections inside the main motor's junction box.

### **2. Blades Rub Against Venturi**

- A.) To make a horizontal adjustment, loosen the 4 bolts (Part #56) at the base of the main fan motor and shift motor side to side until centered. Retighten bolts.
- B.) To make a vertical adjustment, slightly loosen 4 bolts (Part #117) and make necessary adjustments. Retighten bolts.

### **3. Unusual Noise**

- A.) It is normal to hear a slight rattling noise at start-up and shut-down. This is caused by the tip of the liquid feed tube entering the center of the fan blade assembly reservoir.
- B.) Squealing at start-up or during operation may be caused by the motor shaft's bearing seal. Spray with lubricant at the front of the motor where the shaft exits the motor's frame.

### **4. No Fog**

- A.) Check to see if flow control valve is open. The valve is open when the handle is down and closed when up. If the valve is open and there is still no fog, the pump may need to be primed. In rare cases the pump may retain an air bubble. To prime the pump, remove the inline strainer cap (Part #71) and turn the system ON for a few seconds. Replace cap and try operating unit again.
- B.) If pump is receiving electricity but there is no fog, check for sediment in the pump's intake screen. Spray around the pump with a garden hose or remove the pump and thoroughly clean the intake screen. Clean and flush out the tank area by removing the drainage plug located on the bottom rear of RSM.
- C.) If no liquid enters the tank when using the automatic fill, check float valve assembly for debris. When the float arm is up, water should shut off; when it is down, water should freely enter RSM tank.

### **5. Liquid Spilling From Overflow Port**

- A.) Check the float valve assembly. If the float (Part #99) is filling with water, it should be replaced. Also check to see if debris is not allowing the valve (Part #97) to seal properly. Clean as needed.
- B.) Reduce the in-line water pressure.



# TROUBLESHOOTING (CONT.)



**BEFORE INSPECTION AND /OR SERVICE  
DISCONNECT AND LOCK OUT POWER SOURCE.**



## 6. Poor Quality Fog

- A.) The liquid feed tube (Part #6) may not be inserted properly into the reservoir. The feed tube must be inserted approximately 1/4" into the center bearing, but it should not touch the back of the reservoir.
- B.) Reservoir may be clogged. Fluid entering a clogged reservoir will spill out of the center bearing instead of entering the passageways of the fan blades. To clean, remove the blade assembly from the motor shaft and totally disassemble. Next, flush the reservoir under a sink, making sure the passageways are cleared. Check and clear the passageways of each individual blade as well. Reassemble and reattach.

## 7. Fan Motor Becomes Excessively Hot

The main fan motor normally becomes very hot to the touch. However, if it gets so hot that it begins to smell or smoke or the power cord becomes hot, discontinue operation and consult an electrician to properly evaluate the problem.

## 8. Electrical Breaker Tripping

If the electrical breaker trips off, there is an overload in the system and there may be a serious motor problem. Turn off all other devices connected to the same circuit. If the breaker continues to trip, the motor is probably in need of repair. Consult an electrician for evaluation.

## 9. Fan and/or Motor Vibration

- A.) If the fan unit begins vibrating severely, first be sure the blade assembly is fully engaged and securely tightened on the motor shaft. Next, inspect the blade assembly, particularly the ends of the blades. Look for wear or cracks - replace as necessary. Look for deposits of calcium or minerals - clean and remove mineral deposits and/or calcium.
- B.) If the vibration seems to be coming from the motor, first check that the motor mounting hardware is securely tightened. If hardware is secure, remove the blade assembly and operate the motor without the blade. If vibration continues, the motor has a serious mechanical problem and probably needs to be replaced.

## 10. Liquid Spilling From Fan Housing

If liquid builds up inside the housing, the drain tube is probably clogged. Clean debris from the drain strainer and drain tube.

## 11. Plumbing Leaks

Un-thread fittings and clean both the male and female threads. Apply new thread tape (approximately 2-3 wraps) and reconnect. If a tube fitting is leaking, tighten the cap - no more than 1 turn past finger tightened. If the leak persists, replace the tube fitting insert.

Contact Your Sales Representative for Further Assistance.



# AQUAFOG FAN EXPLODED VIEW

## PART IDENTIFICATION

ID #	Description	Qty/Unit
1	Housing	1
2	Safety guard	1
6	SST feed tube	1
7	Liquid feed tube fitting	1
8	Drain fitting	2
13	Fan motor (specify Phase)	1
14	Pinned venturi assembly	1
15	Fan blade assembly (1 HP, 30°)	1
16	Rear guard	1
17	Fan blade (1 HP, 30°)	4
19	SST Face plate & bearing	1
20	1/4" Heavy large diameter washer	8
27	Blade spacer	4
28	Reservoir (4 hole)	1
29	Front hub	1
30	Rear hub	1
31	1/4-20 x 1 1/4" HH bolt SST	4
32	1/4-20 nylon stop nut SST	12
33	1/4-20 x 3/8" socket set screw SST	2
34	Blade feeder tube	4
35	SST washer for feed tube fitting	2
39	Drain strainer	1
41	10-24 x 1/2" phillips RH SST	4
42	10-24 nylon stop nut SST	4
43	11/16 x 1 1/4" flat washer SST	1
44	Drain tubing	3'
45	Liquid-tight cord fitting	2
46	Key	1
52	1/4-20 x 3/4" HH bolt SST	4
54	1/4-20 x 3/8" button head cap screw	6
56	5/16-18 x 3/4" HH bolt SST	8
57	5/16" lock washer SST	8
58	5/16" flat washer SST	12
114	Drain fitting nut	1
115	Drain gasket	1
116	5/16-18 finish nut SST	4
117	1/4-20 x 5/8" HH bolt SST	4
288	1/8" NPT-F elbow	1
294	1/8" NPT-M x 3/8" tube fitting	1
340	3/8" black tubing clamp	1
349	5/16" brass rod	1
391	Top pivot plate	1
392	Bottom pivot plate	1
394	Brass pivot washer	2
395	5/16" nylon lock nut	2
403	Brass ring	2
405	3/8" x 1 1/4" fender washer SST	1
417	Machine Nut	4
427	Safety Guard Clip	4
435	Reservoir O-ring	1
479	Hair pin SST	1
600-L	RSM support left	1
600-R	RSM support right	1
W-38	3/8" tubing	5'

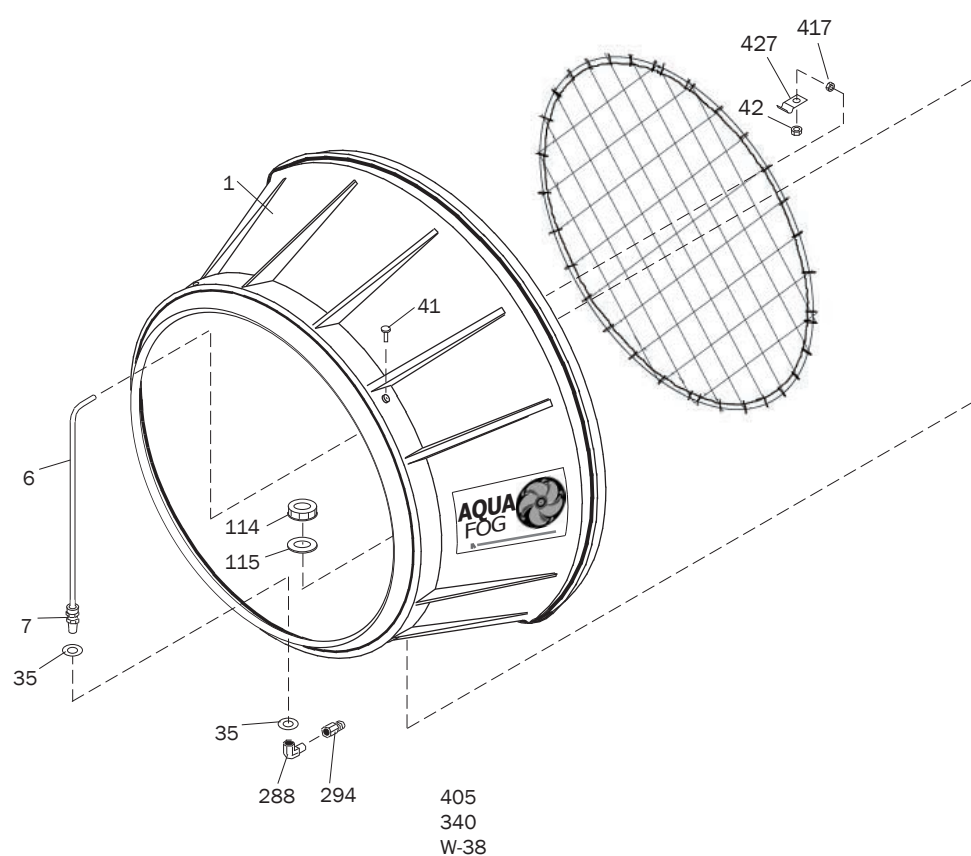
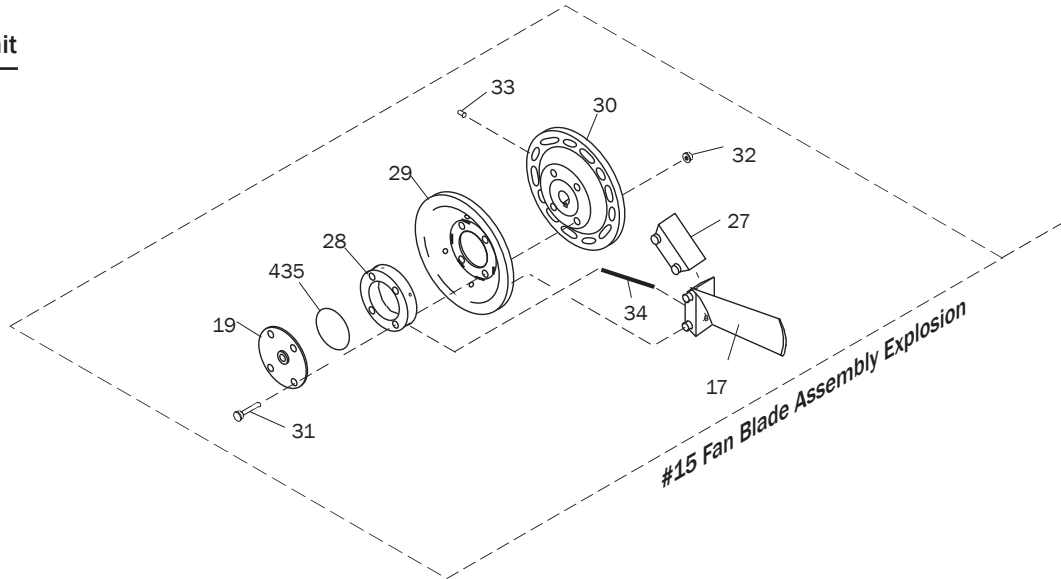

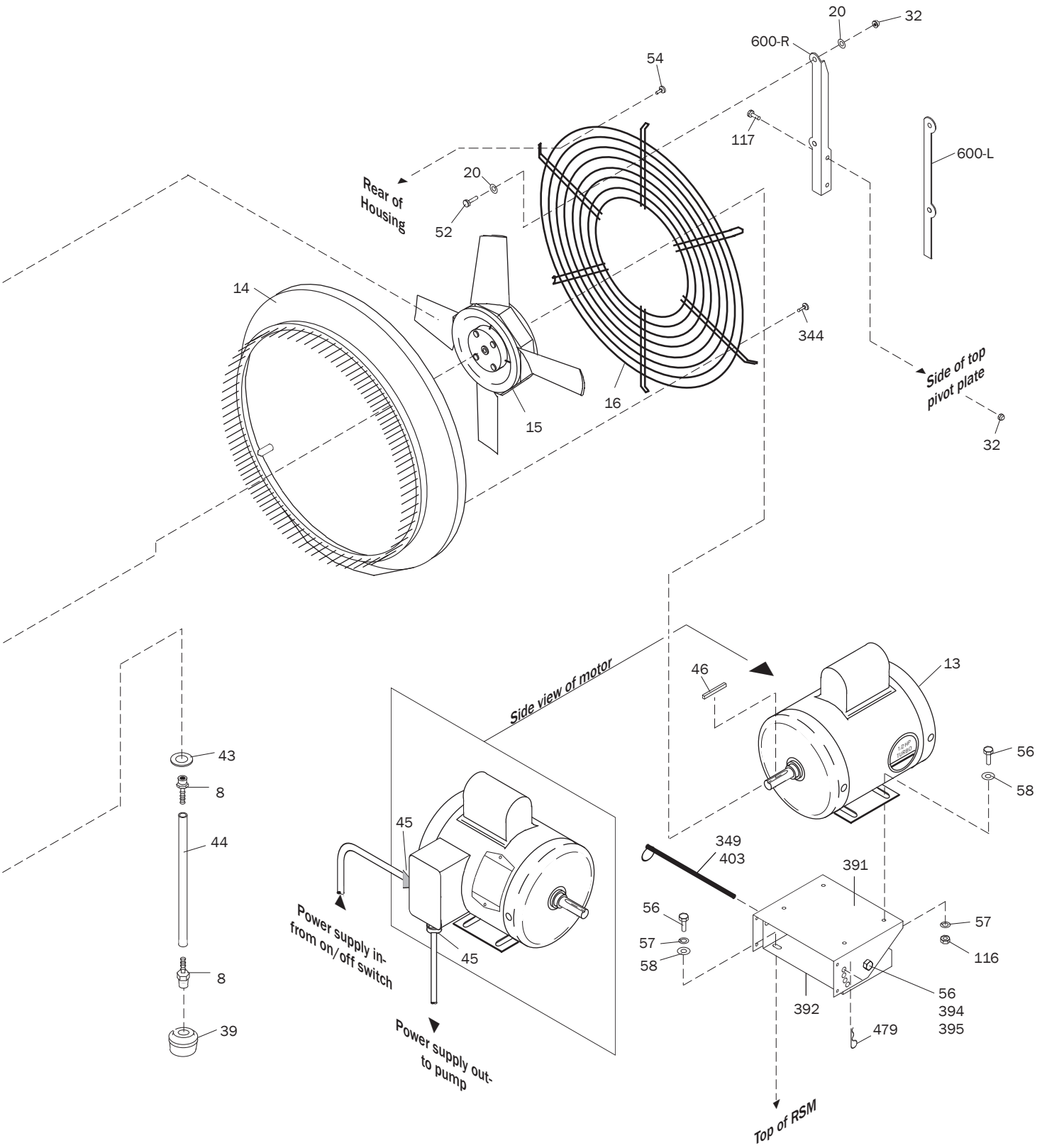

# HRSM TANK EXPLODED VIEW

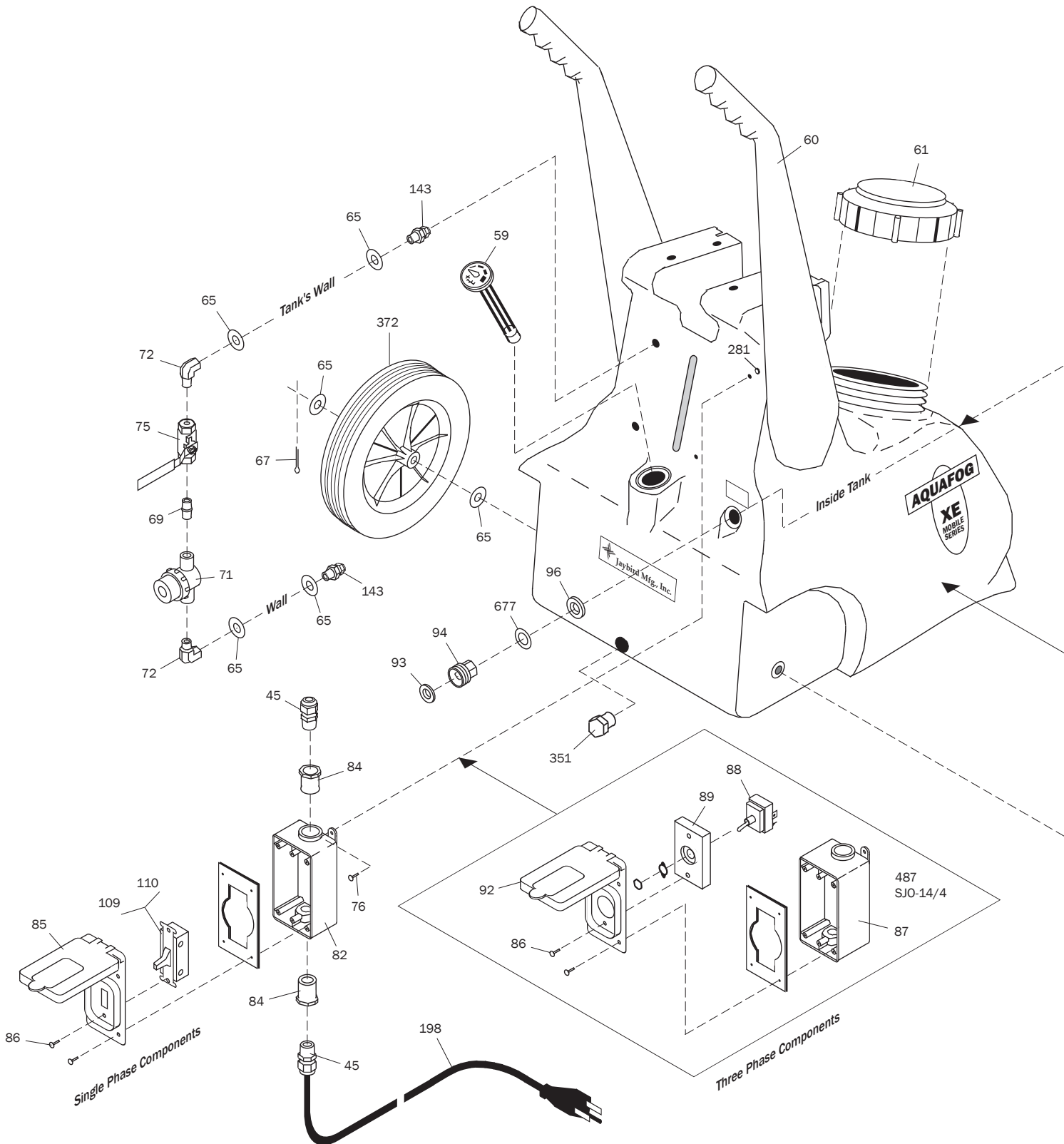

# PART IDENTIFICATION LIST

## PART IDENTIFICATION

ID #	Description	Qty/Unit
------	-------------	----------

32	1/4-20 nylon stop nut SST	2
45	Liquid-tight cord fitting	2
55	M20 Serrated lock washer SST	1
59	Fluid level gauge	1
60	RSM tank	1
61	Fill cap	1
65	1/2" flat washer SST	8
67	5/32 x 1 1/4" cotter pin SST	2
69	1/4" NPT close nipple	1
71	Inline strainer 1/4" female NPT	1
72	1/4" NPT street elbow	2
75	Flow control valve	1
76	10-24 x 3/4" phillips RH SST	2
82	Electrical switch box	1
84	3/4" M socket x 1/2" F NPT Bushing	2
85	Switch cover	1
86	6-32 x 1/2" oval slotted screw	6
87	Electrical switch box (3 phase)	1
88	Switch (3 phase)	1
89	Spacer plate (3 phase)	1
92	Switch cover (3 phase)	1
93	Hose connector gasket	1
94	Hose connector	1
96	Gasket	1
97	Float valve	1
98	Stem	1
99	Float	1
100	Pump HRSM 115 volt 60hz.	1
101	Pump HRSM 230 volt 50hz.	1
108	#8 x 3/8" self tapping phillips SST	2
109	Switch 115 volt	1
110	Switch 230 volt	1
111	Axle SST	1
126	1/4" lock washer SST	2
143	1/4" NPT-M x 3/8 tube fitting	2
154	1/4-20 finish nut SST	2
198	18' power cord and plug 115V	1
281	10-24 keps nut SST	2
288	1/8" NPT elbow	1
294	1/8" NPT-F x 3/8 tube fitting	1
297	1/4" NPT-F x 3/8 tube fitting	1
344	10-24 x 1/2" phillips truss head SST	4
351	1" NPT black nylon hex plug	1
372	Heavy-duty RSM wheel	2
443	1/4-20 x 1-1/4" HH bolt	2
487	3Ph Pulg 208-230V	1
606	H Pump support bracket	1
677	11/16 x 1-1/4" flat washer SST	1
SJO-14/4	4 wire 14 guage (3Ph power cord)	18'

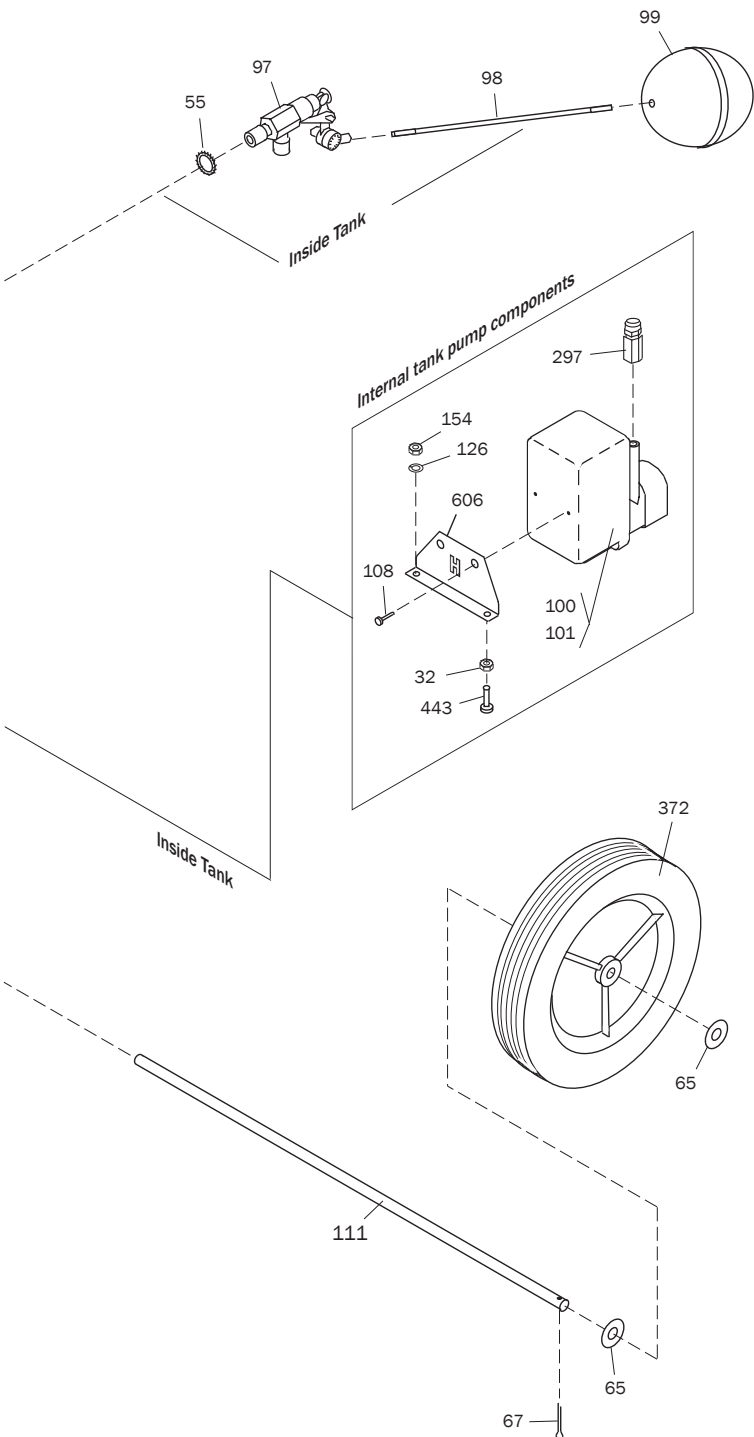

# MAINTENANCE



## **WARNING**

**DISCONNECT AND LOCK OUT POWER SOURCE  
BEFORE SERVICING**

---

### **1. Clean Strainers**

The RSM is equipped with 3 strainers that should be cleaned periodically - the Drain Strainer (Part #39) in the Tank, the Inline Strainer (Part #71) at the bottom of the Flow Control Valve and the Pump Screen on the Pump. Check strainers and remove any trapped debris.

### **2. Flush Out Tank**

The tank should be rinsed regularly, especially if using chemicals. Remove drain plug (Part #351) and, using a garden hose, thoroughly flush tank and pump of any sediment.

### **3. Lubricate Main Motor**

The main motor is a permanently lubricated motor, but it is beneficial to apply spray oil around the shaft where it exits the motor body. Lubricate motor once a season or whenever squealing occurs.

### **4. Inspect Blade Assembly**

Clean the blade assembly about once a year, especially if a film of calcium or mineral deposits is visible on the exterior of the blades. Remove any build-up from the blades and any debris from blade passageways. While cleaning, inspect for irregularities or hairline cracks and replace as necessary.

### **5. Storage**

Protect your mobile Aquafog from winter damage. Expansion due to freezing can burst the fittings or the internal feed pump. If storing unit in below freezing temperatures, be sure all fluid is drained from the tank area. Damage due to freezing is not covered under warranty.



## ONE YEAR LIMITED WARRANTY

Aquafog and accessories are warranted to the original purchaser against defects in material and workmanship under normal use for one full year from date of purchase. Any part determined to be defective and returned to the manufacturer, shipping cost prepaid, will be repaired or replaced at Jaybird Manufacturing, Inc.'s discretion without charge. Proof of purchase date and an explanation of the problem or complaint must accompany the returned portion of the machine.

Jaybird Manufacturing, Inc. reserves the right to verify the legitimacy of claimed defects. The provisions of this warranty do not apply to damage resulting from direct or indirect misuse, negligence, accident, lack of maintenance, or unauthorized repairs or alterations which affect the machine's performance or reliability.

**LIMITATIONS OF LIABILITY. TO THE EXTENT ALLOWABLE UNDER APPLICABLE LAW, JAYBIRD MANUFACTURING, INC.'S LIABILITY FOR DEATH, INJURIES TO PERSONS OR PROPERTY, OR FOR CONSEQUENTIAL OR INCIDENTAL DAMAGES ARISING FROM THE USE OF OUR EQUIPMENT IS EXPRESSLY DISCLAIMED. JAYBIRD MANUFACTURING, INC.'S LIABILITY IN ALL EVENTS IS LIMITED TO, AND SHALL NOT EXCEED, THE PURCHASE PRICE PAID. NO OTHER WARRANTY, EXPRESSED OR IMPLIED, IS AUTHORIZED, INCLUDING WARRANTIES OF MERCHANTABILITY AND FITNESS FOR A PARTICULAR PURPOSE.**

*This warranty gives you specific legal rights, and you may also have other rights, which vary from state to state.*



### Jaybird Manufacturing, Inc.

135 Summer Lane  
Centre Hall, PA 16828

Parts & Service: 1.814.364.1800

Website: [www.jaybird-mfg.com](http://www.jaybird-mfg.com)